

PROPRIETARY AND CONFIDENTIAL
 THE INFORMATION CONTAINED IN THIS DRAWING IS THE SOLE PROPERTY OF ARDENT CONCEPTS, INC. ANY REPRODUCTION IN PART OR AS A WHOLE WITHOUT THE WRITTEN PERMISSION OF ARDENT CONCEPTS, INC. IS PROHIBITED.

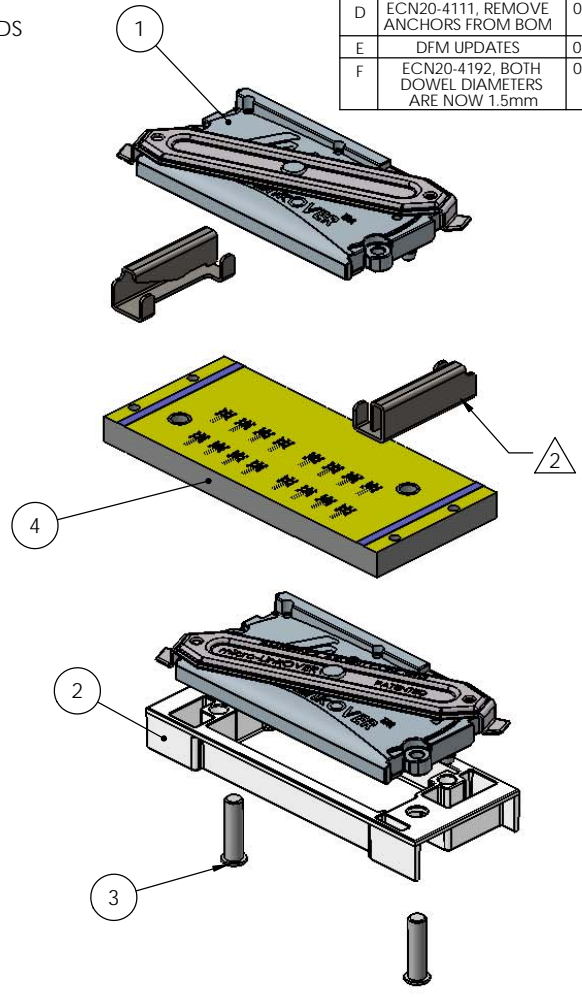
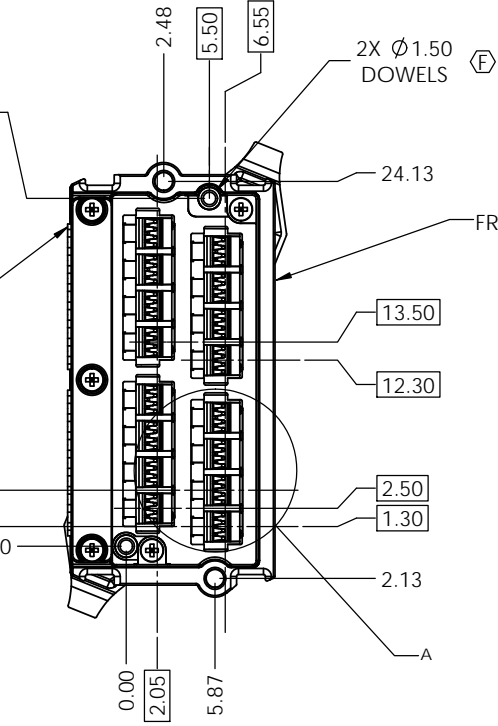
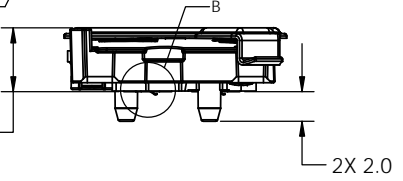
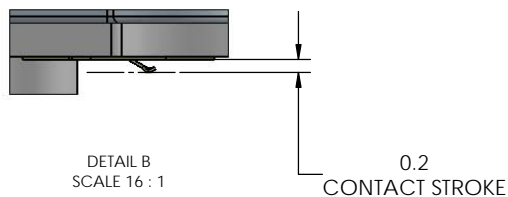
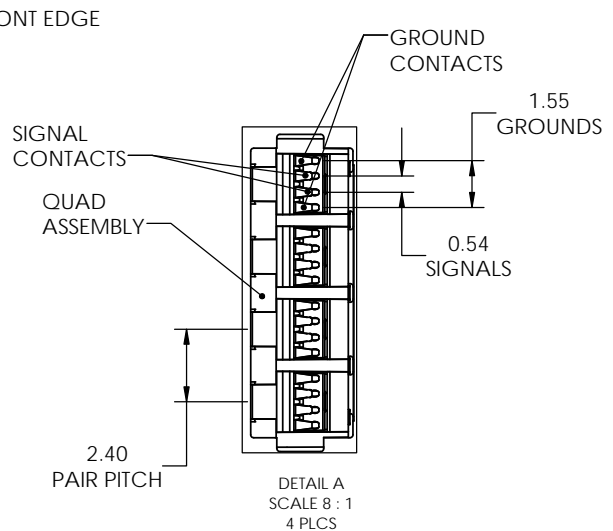
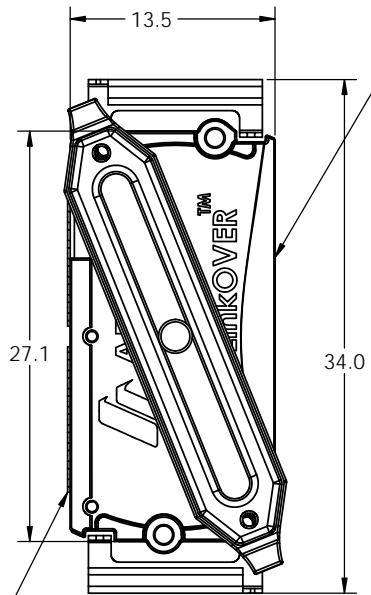

REVISIONS			
REV.	DESCRIPTION	DATE	APPROVED
A	RELEASED, ECN20-4026	02/20/20	SD
B	ADD ANCHOR CARRIER, SHIPPING HARDWARE	02/20/20	SD
C	RELEASED, ECN20-4097	04/02/20	SD
D	ECN20-4111, REMOVE ANCHORS FROM BOM	04/15/20	SD
E	DFM UPDATES	05/05/20	SD
F	ECN20-4192, BOTH DOWEL DIAMETERS ARE NOW 1.5mm	06/18/20	SD

ITEM NO.	PART NUMBER	DESCRIPTION	SEATED/QTY
1	mLO-CON-S16X2-XXX-S-02	micro-LinkOVER CONNECTOR, SMT MOUNT	1
2	mLO-AC-16X2-01	ANCHOR CARRIER	2
3	M16PHCS06	M1.6 PAN HEAD X 6mm, 96773A625	4
4	mLO-FP-16X2-02	16 PAIR micro-LinkOVER FOOTPRINT SPECIFICATION, SMT MOUNT	REF

- NOTES:
- XXX INDICATES CABLE LENGTH IN mm.
 - ANCHORS SHIP AS PART OF AN ASSEMBLY WITH SEPARATE CARRIER IN TAPE AND REEL.

CHANGE	NOTE	PROJECTION	METRIC UNLESS OTHERWISE SPECIFIED.	 ARDENT CONCEPTS <small>INCORPORATED</small> 4 MERRILL INDUSTRIAL DRIVE, SUITE 102 HAMPTON, NH 03842 (603) 474-1760
MATERIAL	SIZE	TITLE:	TOLERANCES: ANGLES: ±3 X.X = ±1 X.XX = ±05 X.XXX = ±025	
FINISH	INTERPRET GEOMETRIC TOLERANCING PER: ANSI Y14.5M 1982	DWG. NO.	16 PAIR micro-LinkOVER, SMT MOUNT	REV
WWW.ARDENTCONCEPTS.COM		SCALE: 4:1	WEIGHT:	SHEET 1 OF 2

PROPRIETARY AND CONFIDENTIAL
 THE INFORMATION CONTAINED IN THIS DRAWING IS THE SOLE
 PROPERTY OF ARDENT CONCEPTS, INC. ANY REPRODUCTION
 IN PART OR AS A WHOLE WITHOUT THE WRITTEN PERMISSION OF
 ARDENT CONCEPTS, INC. IS PROHIBITED.

P1	P2
B1	F16
B2	F15
B3	F14
B4	F13
B5	F12
B6	F11
B7	F10
B8	F9
B9	F8
B10	F7
B11	F6
B12	F5
B13	F4
B14	F3
B15	F2
B16	F1
F1	B16
F2	B15
F3	B14
F4	B13
F5	B12
F6	B11
F7	B10
F8	B9
F9	B8
F10	B7
F11	B6
F12	B5
F13	B4
F14	B3
F15	B2
F16	B1

**P1 TO P2
 CABLE ROUTING**

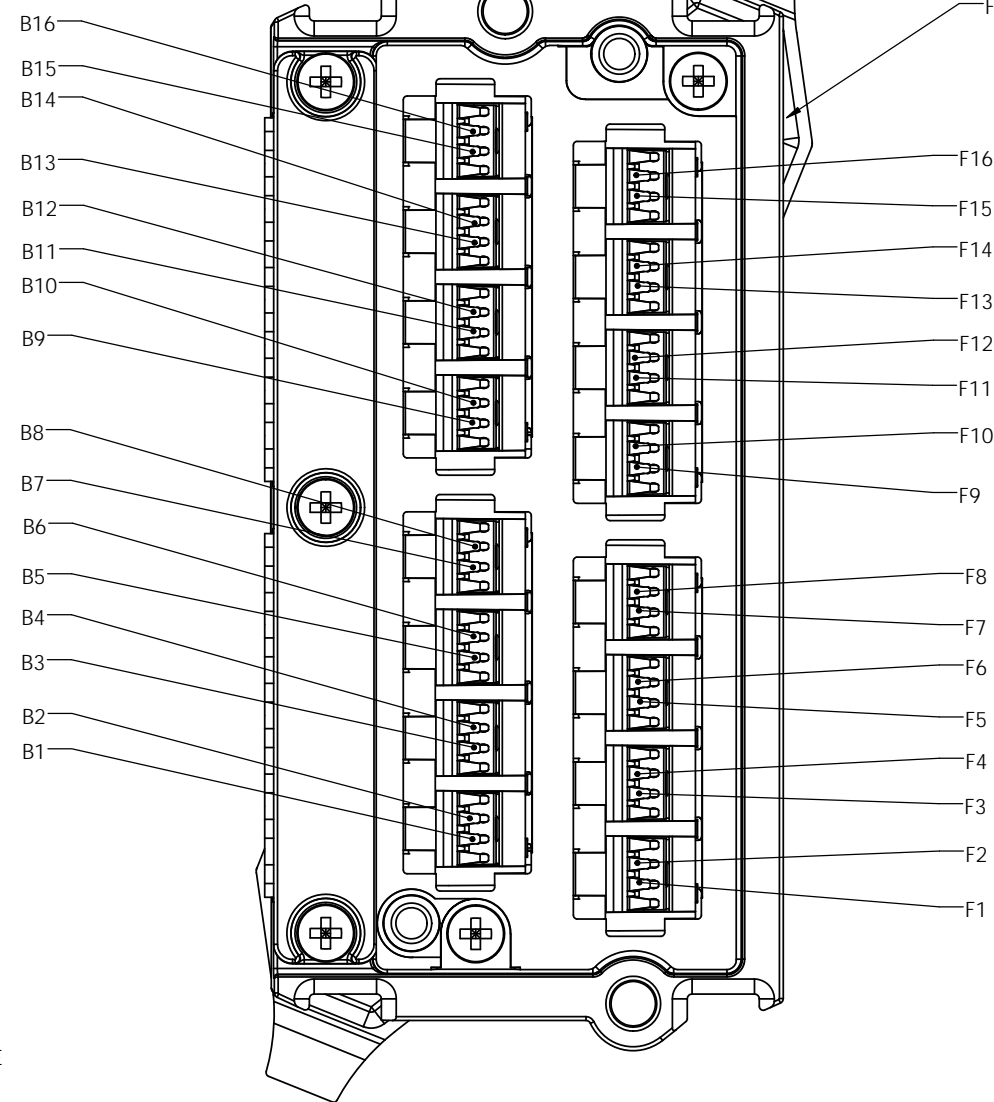
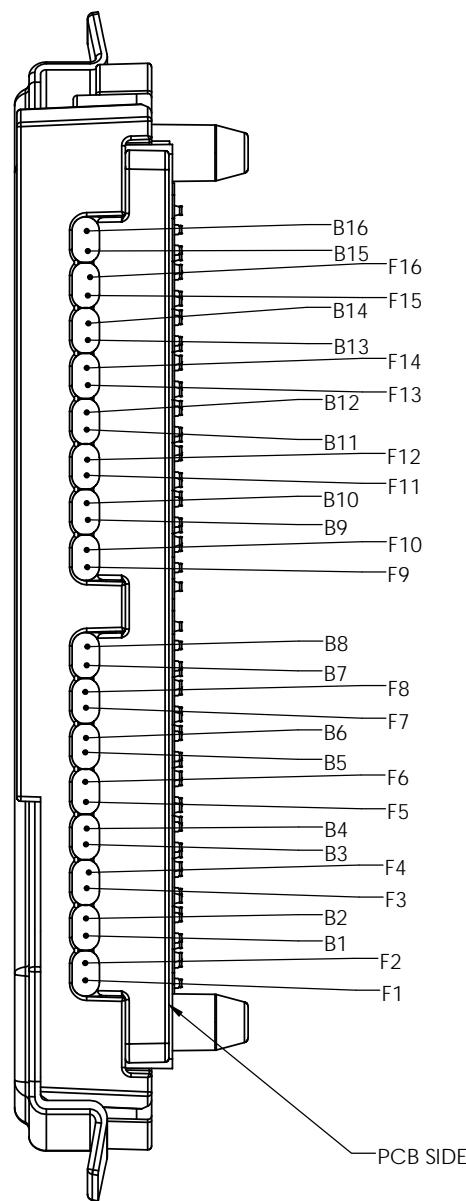

**BOTTOM SIDE VIEWED FROM THE BOTTOM
 PINOUT CONVENTION**

CHANGE NOTE PROJECTION	METRIC UNLESS OTHERWISE SPECIFIED. TOLERANCES: ANGLES: ±3 X.X = ±1 X.XX = ±05 X.XXX = ±025		ARDENT CONCEPTS <small>INCORPORATING MICRO-LINKOVER</small> 4 MERRILL INDUSTRIAL DRIVE, SUITE 102 HAMPTON, NH 03842 (603) 474-1760
	TITLE: 16 PAIR micro-LinkOVER, SMT MOUNT		
MATERIAL: --	SIZE: C	DWG. NO: mLO-S16X2-XXX-S-02	REV: F
FINISH: --	INTERPRET GEOMETRIC TOLERANCING PER: ANSI Y14.5M 1982	WWW.ARDENTCONCEPTS.COM	SCALE: 4:1 WEIGHT: SHEET 2 OF 2